

DATA SHEET

TDA9810

**Multistandard VIF-PLL with QSS-IF
and AM demodulator**

Product specification
Supersedes data of 1997 Jun 19
File under Integrated Circuits, IC02

1999 May 07

Multistandard VIF-PLL with QSS-IF and AM demodulator

TDA9810

FEATURES

- 5 V supply voltage
- Gain controlled wide band Video Intermediate Frequency (VIF)-amplifier (AC-coupled)
- True synchronous demodulation with active carrier regeneration (very linear demodulation, good intermodulation figures, reduced harmonics, excellent pulse response)
- Gated phase detector for L/L accent standard; robustness for over-modulation until 105%
- Voltage Controlled Oscillator (VCO) frequency switchable between L and L accent (alignment external) picture carrier frequency
- Separate video amplifier for sound trap buffering with high video bandwidth
- VIF Automatic Gain Control (AGC) detector for gain control, operating as peak sync detector for B/G (optional external AGC) and peak white detector for L; signal controlled reaction time for L
- Tuner AGC with adjustable TakeOver Point (TOP)
- AFC detector without extra reference circuit
- SIF-input for single reference Quasi Split Sound (QSS) mode (Phase Locked Loop (PLL) controlled); Sound Intermediate Frequency (SIF) AGC detector for gain controlled SIF amplifier; single reference QSS mixer able to operate in high performance single reference QSS mode
- AM demodulator without extra reference circuit
- AM mute (especially for NICAM)
- Stabilizer circuit for ripple rejection and to achieve constant output signals.

GENERAL DESCRIPTION

The TDA9810 is an integrated circuit for multistandard vision IF signal processing and sound AM demodulation, with single reference QSS-IF in TV and VCR sets.

ORDERING INFORMATION

TYPE NUMBER	PACKAGE		
	NAME	DESCRIPTION	VERSION
TDA9810	SDIP24	plastic shrink dual in-line package; 24 leads (400 mil)	SOT234-1
TDA9810T	SO24	plastic small outline package; 24 leads; body width 7.5 mm	SOT137-1

Multistandard VIF-PLL with QSS-IF and AM demodulator

TDA9810

QUICK REFERENCE DATA

SYMBOL	PARAMETER	CONDITIONS	MIN.	TYP.	MAX.	UNIT
V_P	supply voltage		4.5	5	5.5	V
I_P	supply current		77	90	103	mA
$V_{i(VIF)(rms)}$	vision IF input signal voltage sensitivity (RMS value)	-1 dB video at output	-	60	100	μ V
$V_{o(CVBS)(p-p)}$	CVBS output signal voltage (peak-to-peak value)		1.7	2.0	2.3	V
B_{-3}	-3 dB video bandwidth on pin CVBS	B/G and L standard; $C_L < 20$ pF; $R_L > 1$ k Ω ; AC load	7	8	-	MHz
$S/N_{W(video)}$	weighted signal-to-noise ratio for video		56	60	-	dB
$\alpha_{IM(1.1)}$	intermodulation attenuation at 'blue'	$f = 1.1$ MHz	58	64	-	dB
$\alpha_{IM(3.3)}$	intermodulation attenuation at 'blue'	$f = 3.3$ MHz	58	64	-	dB
$\alpha_{H(sup)}$	suppression of video signal harmonics		35	40	-	dB
$V_{i(SIF)(rms)}$	sound IF input signal voltage sensitivity (RMS value)	-3 dB at intercarrier output	-	30	70	μ V
$V_{o(intercarrier)(rms)}$	IF intercarrier level (RMS value)	SC ₁ output signal	100	140	180	mV
		SC _{AM} output signal	100	140	180	mV
		SC _{NICAM} output signal	14	20	26	mV
$V_{o(AF)(rms)}$	AF output signal voltage (RMS value)	L standard; 54% modulation	-	500	-	mV
THD	total harmonic distortion	54% modulation	-	0.5	1.0	%
S/N_W	weighted signal-to-noise ratio	54% modulation	47	53	-	dB

Multistandard VIF-PLL with QSS-IF and AM demodulator

TDA9810

BLOCK DIAGRAM

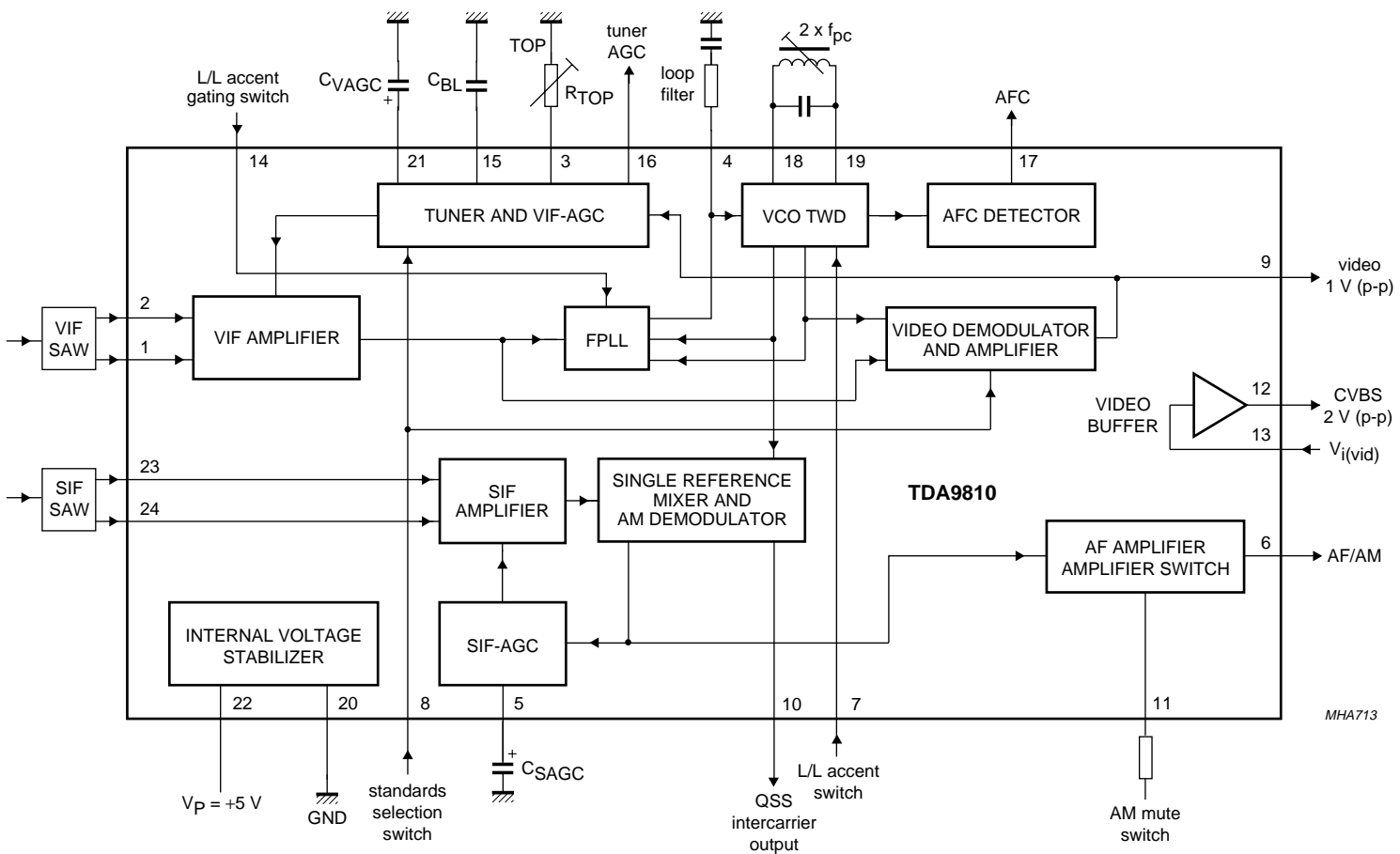

Fig.1 Block diagram.

Multistandard VIF-PLL with QSS-IF and AM demodulator

TDA9810

PINNING

SYMBOL	PIN	DESCRIPTION
$V_{i\ VIF1}$	1	VIF differential input signal voltage 1
$V_{i\ VIF2}$	2	VIF differential input signal voltage 2
TADJ	3	tuner AGC takeover point adjust
T_{PLL}	4	PLL loop filter
C_{SAGC}	5	SIF AGC capacitor
$V_{o\ AF}$	6	AM audio frequency output voltage
LSWI	7	L/L accent switch
STD	8	standard switch
$V_{o(vid)}$	9	composite video output voltage
$V_{o\ QSS}$	10	single reference QSS output voltage
MUTE	11	AM mute switch
$V_{o\ CVBS}$	12	CVBS output signal voltage

SYMBOL	PIN	DESCRIPTION
$V_{i(vid)}$	13	video buffer input voltage
LGATSWI	14	L/L accent gating switch
C_{BL}	15	black level detector
TAGC	16	tuner AGC output
AFC	17	AFC output
VCO1	18	VCO1 reference circuit for $2f_{pc}$
VCO2	19	VCO2 reference circuit for $2f_{pc}$
GND	20	ground
C_{VAGC}	21	VIF AGC capacitor
V_P	22	supply voltage
$V_{i\ SIF1}$	23	SIF differential input signal voltage 1
$V_{i\ SIF2}$	24	SIF differential input signal voltage 2

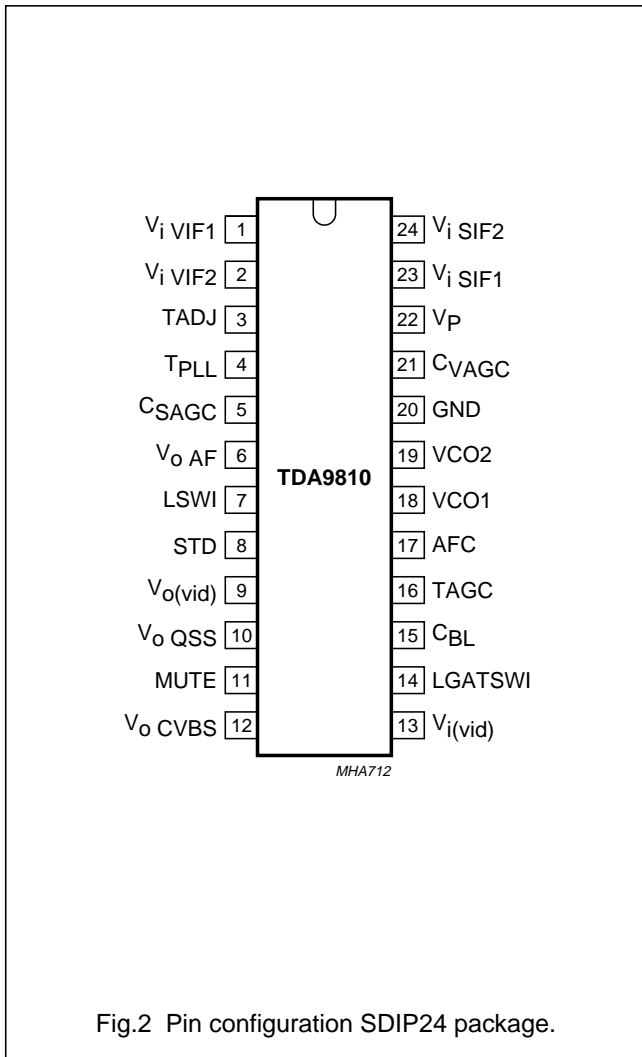

Fig.2 Pin configuration SDIP24 package.

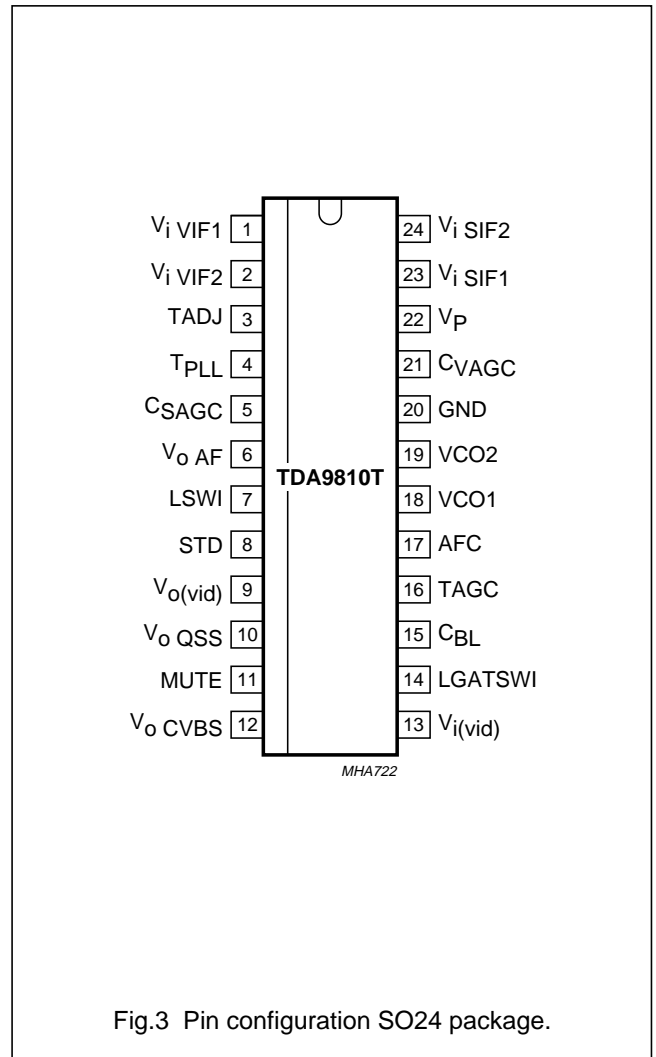

Fig.3 Pin configuration SO24 package.

Multistandard VIF-PLL with QSS-IF and AM demodulator

TDA9810

FUNCTIONAL DESCRIPTION

Vision IF amplifier

The vision IF amplifier consists of three AC-coupled differential amplifier stages. Each differential stage comprises a feedback network controlled by emitter degeneration.

Tuner and VIF AGC

The AGC capacitor voltage is transferred to an internal IF control signal, and is fed to the tuner AGC to generate the tuner AGC output current (pin TAGC, open-collector output). The tuner AGC takeover point can be adjusted. This allows the tuner and the SWIF filter to be matched to achieve the optimum IF input level.

The AGC detector charges/discharges the AGC capacitor to the required voltage for setting of VIF and tuner gain in order to keep the video signal at a constant level. Therefore for negative video modulation the sync level and for positive video modulation the peak white level of the video signal is detected. In order to reduce the reaction time for positive modulation, where a very large time constant is needed, an additional level detector increases the discharging current of the AGC capacitor (fast mode) in the event of a decreasing VIF amplitude step. The additional level information is given by the black-level detector voltage.

Frequency Phase Locked Loop detector (FPLL)

The VIF-amplifier output signal is fed into a frequency detector and into a phase detector via a limiting amplifier. During acquisition the frequency detector produces a DC current proportional to the frequency difference between the input and the VCO signal. After frequency lock-in the phase detector produces a DC current proportional to the phase difference between the VCO and the input signal. The DC current of either frequency detector or phase detector is converted into a DC voltage via the loop filter, which controls the VCO frequency. In the event of positive modulated signals the phase detector is gated by composite sync in order to avoid signal distortion for overmodulated VIF signals. This mode can be switched off by the L/L accent gating switch.

VCO, Travelling Wave Divider (TWD) and AFC

The VCO operates with a resonance circuit (with L and C in parallel) at double the Picture Carrier (PC) frequency.

The VCO is controlled by two integrated variable capacitors. The control voltage required to tune the VCO from its free-running frequency to actually double the PC frequency is generated by the Frequency-Phase detector and fed via the loop filter to the first variable capacitor (FPLL). This control voltage is amplified and additionally converted into a current which represents the AFC output signal. The VCO centre frequency can be decreased (required for L accent standard) by activating an additional internal capacitor. This is achieved by using the L/L accent gating switch. In this event the second variable capacitor can be controlled by a variable resistor at the L/L accent gating switch for setting the VCO centre frequency to the required L accent value. At centre frequency the AFC output current is equal to zero.

The oscillator signal is divided-by-two with a TWD which generates two differential output signals with a 90 degree phase difference independent of the frequency.

Video demodulator and amplifier

The video demodulator is realized by a multiplier which is designed for low distortion and large bandwidth. The vision IF input signal is multiplied with the 'in phase' signal of the travelling wave divider output. In the demodulator stage the video signal polarity can be switched in accordance with the TV standard.

The demodulator output signal is fed via an integrated low-pass filter for attenuation of the carrier harmonics to the video amplifier. The video amplifier is realized by an operational amplifier with internal feedback and high bandwidth. A low-pass filter is integrated to achieve an attenuation of the carrier harmonics for B/G and L standard. The standard dependent level shift in this stage delivers the same sync level for positive and negative modulation. The video output signal is 1 V (p-p) for nominal vision IF modulation.

Video buffer

For an easy adaption of the sound traps an operational amplifier with internal feedback is used in the event of B/G and L standard. This amplifier is featured with a high bandwidth and 7 dB gain. The input impedance is adapted for operating in combination with ceramic sound traps. The output stage delivers a nominal 2 V (p-p) positive video signal. Noise clipping is provided.

Multistandard VIF-PLL with QSS-IF and AM demodulator

TDA9810

SIF amplifier and AGC

The sound IF amplifier consists of two AC-coupled differential amplifier stages. Each differential stage comprises a controlled feedback network provided by emitter degeneration.

The SIF AGC detector is related to the SIF input signals (average level of AM or FM carriers) and controls the SIF amplifier to provide a constant SIF signal to the AM demodulator and single reference QSS mixer. The SIF AGC reaction time is set to 'slow' for nominal video conditions. But with a decreasing VIF amplitude step the SIF AGC is set to 'fast' mode controlled by the VIF AGC detector. In FM mode this reaction time is also set to 'fast' controlled by the standard switch.

Single reference QSS mixer

The single reference QSS mixer is realized by a multiplier. The SIF amplifier output signal is fed to the single reference QSS mixer and converted to intercarrier frequency by the regenerated picture carrier (VCO). The mixer output signal is fed via a high-pass for attenuation of the video signal components to the output pin 10. With this system a high performance hi-fi stereo sound processing can be achieved.

AM demodulator

The AM demodulator is realized by a multiplier. The modulated SIF amplifier output signal is multiplied in phase with the limited (AM is removed) SIF amplifier output signal. The demodulator output signal is fed via an integrated low-pass filter for attenuation of the carrier harmonics to the AF amplifier. This AM output signal can be muted by using the AM mute switch.

Internal voltage stabilizer and $\frac{1}{2}V_P$ -reference

The bandgap circuit internally generates a voltage of approximately 1.25 V, independent of supply voltage and temperature. A voltage regulator circuit, connected to this voltage, produces a constant voltage of 3.6 V which is used as an internal reference voltage.

For all audio output signals the constant reference voltage cannot be used because large output signals are required. Therefore these signals refer to half the supply voltage to achieve a symmetrical headroom, especially for the rail-to-rail output stage. For ripple and noise attenuation the $\frac{1}{2}V_P$ voltage has to be filtered via a low-pass filter by using an external capacitor together with an integrated resistor ($f_{-3dB} = 5$ Hz). For a fast setting to $\frac{1}{2}V_P$ an internal start-up circuit is available.

Multistandard VIF-PLL with QSS-IF and AM demodulator

TDA9810

LIMITING VALUES

In accordance with the Absolute Maximum Rating System (IEC 134).

SYMBOL	PARAMETER	CONDITIONS	MIN.	MAX.	UNIT
V_P	supply voltage (pin 22)	maximum chip temperature of 125 °C; note 1	0	5.5	V
V_I	input voltage at pins 1 to 8, 11, 13 to 17 and 20 to 24		0	V_P	V
$t_{sc(max)}$	maximum short-circuit time		–	10	s
V_{TAGC}	tuner AGC output voltage		0	13.2	V
T_{stg}	storage temperature		–25	+150	°C
T_{amb}	operating ambient temperature		–20	+70	°C
V_{es}	electrostatic handling voltage	note 2	–300	+300	V

Notes

- $I_P = 103$ mA; $T_{amb} = 70$ °C; $R_{th\ j-a} = 69$ K/W for SDIP24 and $R_{th\ j-a} = 90$ K/W for SO24.
- Machine Model class B: $L = 2.5$ μ H.

THERMAL CHARACTERISTICS

SYMBOL	PARAMETER	CONDITIONS	VALUE	UNIT
$R_{th\ j-a}$	thermal resistance from junction to ambient	in free air		
	SOT234-1		69	K/W
	SOT137-1		90	K/W

Multistandard VIF-PLL with QSS-IF and AM demodulator

TDA9810

CHARACTERISTICS

$V_P = 5\text{ V}$; $T_{\text{amb}} = 25\text{ }^\circ\text{C}$; see Table 1 for input frequencies and level; input level $V_{i(\text{IF})}(\text{rms}) = 10\text{ mV}$ (sync-level for B/G, peak white level for L); IF input from $50\text{ }\Omega$ via broadband transformer 1 : 1; video modulation DSB; residual carrier B/G: 10%; L = 3%; video signal in accordance with "CCIR, line 17"; measurements taken in Fig.14; unless otherwise specified.

SYMBOL	PARAMETER	CONDITIONS	MIN.	TYP.	MAX.	UNIT
Supply (pin 22)						
V_P	supply voltage	note 1	4.5	5	5.5	V
I_P	supply current		77	90	103	mA
Vision IF amplifier (pins 1 and 2)						
$V_{i(\text{VIF})}(\text{rms})$	input signal voltage sensitivity (RMS value)	B/G standard; -1 dB video at output	–	60	100	μV
$V_{i(\text{max})}(\text{rms})$	maximum input signal voltage (RMS value)	B/G standard; $+1\text{ dB}$ video at output	120	200	–	mV
$\Delta V_{o(\text{int})}$	internal IF amplitude difference between picture and sound carrier	within AGC range; B/G standard; $\Delta f = 5.5\text{ MHz}$	–	0.7	1	dB
G_{IFcr}	IF gain control range	see Fig.4	65	70	–	dB
$R_{i(\text{diff})}$	differential input resistance	note 2	1.7	2.2	2.7	$\text{k}\Omega$
$C_{i(\text{diff})}$	differential input capacitance	note 2	1.2	1.7	2.5	pF
$V_{I(1,2)}$	DC input voltage	note 2	–	3.4	–	V
True synchronous video demodulator; note 3						
$f_{\text{VCO}(\text{max})}$	maximum oscillator frequency for carrier regeneration	$f = 2f_{\text{pc}}$	125	130	–	MHz
$\Delta f_{\text{osc}}/\Delta T$	oscillator drift as a function of temperature	oscillator is free-running; $I_{\text{AFC}} = 0$; note 4	–	–	$\pm 20 \times 10^{-6}$	K^{-1}
$V_{\text{VCO}(\text{rms})}$	oscillator voltage swing at pins 18 and 19 (RMS value)		70	100	130	mV
$f_{\text{cr}(\text{pc})}$	picture carrier capture frequency range	B/G and L standard	± 1.5	± 2.0	–	MHz
		L accent standard; $f_{\text{pc}} = 33.9\text{ MHz}$; $R_7 = 5.6\text{ k}\Omega$	± 1.0	± 1.3	–	MHz
$\Delta f_{\text{pc}(\text{fr})}$	picture carrier frequency (free-running) accuracy	L accent standard; $f_{\text{pc}} = 33.9\text{ MHz}$; $R_7 = 5.6\text{ k}\Omega$	–	± 200	± 400	kHz
$f_{\text{alg}(\text{L accent})}$	L accent alignment frequency range	$I_{\text{AFC}} = 0$	± 400	± 600	–	kHz
t_{acq}	acquisition time	BL = 70 kHz; note 5	–	–	30	ms
$V_{i(\text{VIF})}(\text{rms})$	VIF input signal voltage sensitivity for PLL to be locked (RMS value; pins 1 and 2)	maximum IF gain; note 6	–	30	70	μV
$I_{\text{offset}(\text{FPLL})}$	FPLL offset current at pin 4	note 7	–	–	± 4.5	μA

Multistandard VIF-PLL with QSS-IF and AM demodulator

TDA9810

SYMBOL	PARAMETER	CONDITIONS	MIN.	TYP.	MAX.	UNIT
Composite video amplifier (pin 9; sound carrier off)						
$V_{o(\text{video})(p-p)}$	output signal voltage (peak-to-peak value)	see Fig.9	0.88	1.0	1.12	V
V/S	ratio between video (black-to-white) and sync level		1.9	2.33	3.0	–
$V_{\text{sync}(9)}$	sync voltage level	B/G and L standard	–	1.5	–	V
$V_{\text{clu}(9)}$	upper video clipping voltage level		$V_P - 1.1$	$V_P - 1$	–	V
$V_{\text{cll}(9)}$	lower video clipping voltage level		–	0.3	0.4	V
$R_{o(9)}$	output resistance	note 2	–	–	10	Ω
$I_{\text{bias}(9)(\text{int})}$	internal DC bias current for emitter-follower		2.2	3.0	–	mA
$I_{\text{sink}(9)(\text{max})}$	maximum AC and DC output sink current		1.6	–	–	mA
$I_{\text{source}(9)(\text{max})}$	maximum AC and DC output source current		2.9	–	–	mA
B_{-1}	–1 dB video bandwidth	B/G and L standard; $C_L < 50 \text{ pF}$; $R_L > 1 \text{ k}\Omega$; AC load	5	6	–	MHz
B_{-3}	–3 dB video bandwidth	B/G and L standard; $C_L < 50 \text{ pF}$; $R_L > 1 \text{ k}\Omega$; AC load	7	8	–	MHz
$\alpha_{H(\text{sup})}$	suppression of video signal harmonics	$C_L < 50 \text{ pF}$; $R_L > 1 \text{ k}\Omega$; AC load; note 8a	35	40	–	dB
PSRR	power supply ripple rejection at pin 9	video signal; grey level; see Fig.12 B/G standard L standard	32 26	35 30	– –	dB dB
CVBS buffer amplifier (only) and noise clipper (pins 12 and 13)						
$R_{i(13)}$	input resistance	note 2	2.6	3.3	4.0	$\text{k}\Omega$
$C_{i(13)}$	input capacitance	note 2	1.4	2	3.0	pF
$V_{I(13)}$	DC input voltage		1.4	1.7	2.0	V
G_v	voltage gain	B/G and L standard; note 9	6.5	7	7.5	dB
$V_{\text{clu}(12)}$	upper video clipping voltage level		3.9	4.0	–	V
$V_{\text{cll}(12)}$	lower video clipping voltage level		–	1.0	1.1	V
$R_{o(12)}$	output resistance	note 2	–	–	10	Ω
$I_{\text{bias}(12)(\text{int})}$	DC internal bias current for emitter-follower		2.0	2.5	–	mA
$I_{\text{sink}(12)(\text{max})}$	maximum AC and DC output sink current		1.4	–	–	mA

Multistandard VIF-PLL with QSS-IF and AM demodulator

TDA9810

SYMBOL	PARAMETER	CONDITIONS	MIN.	TYP.	MAX.	UNIT
$I_{\text{source}(12)(\text{max})}$	maximum AC and DC output source current		2.4	–	–	mA
B_{-1}	–1 dB video bandwidth	B/G and L standard; $C_L < 20 \text{ pF}$; $R_L > 1 \text{ k}\Omega$; AC load	8.4	11	–	MHz
B_{-3}	–3 dB video bandwidth	B/G and L standard; $C_L < 20 \text{ pF}$; $R_L > 1 \text{ k}\Omega$; AC load	11	14	–	MHz
Measurements from IF input to CVBS output (pin 12; 330 Ω between pins 9 and 13, sound carrier off)						
$V_{\text{o(CVBS)(p-p)}}$	CVBS output signal voltage on pin 12 (peak-to-peak value)	note 9	1.7	2.0	2.3	V
$\Delta V_{\text{o(CVBS)}}$	output signal voltage difference	difference between B/G and L standard	–	–	10	%
$V_{\text{o(CVBS)(sync)}}$	sync voltage level	B/G standard	–	1.35	–	V
		L standard	–	1.35	–	V
$\Delta V_{\text{o(CVBS)}}$	deviation of CVBS output signal voltage at B/G	50 dB gain control	–	–	0.5	dB
		30 dB gain control	–	–	0.1	dB
$\Delta V_{\text{o(bl)(BG)}}$	black level tilt in B/G standard	gain variation; note 10	–	–	1	%
$\Delta V_{\text{o(bl)(L)}}$	black level tilt for worst case in L standard	vision carrier modulated by test line (VITS) only; gain variation; note 10	–	–	1.9	%
G_{diff}	differential gain	"CCIR, line 330"	–	2	5	%
Φ_{diff}	differential phase	"CCIR, line 330"	–	1	2	deg
B_{-1}	–1 dB video bandwidth	$C_L < 20 \text{ pF}$; $R_L > 1 \text{ k}\Omega$; AC load; B/G and L standard	5	6	–	MHz
B_{-3}	–3 dB video bandwidth	$C_L < 20 \text{ pF}$; $R_L > 1 \text{ k}\Omega$; AC load; B/G and L standard	7	8	–	MHz
$S/N_{\text{W(video)}}$	weighted signal-to-noise ratio for video	see Fig.6 and note 11	56	60	–	dB
S/N	unweighted signal-to-noise ratio	see Fig.6 and note 11	49	53	–	dB
$\alpha_{\text{IM}(1.1)}$	intermodulation attenuation at 'blue'	$f = 1.1 \text{ MHz}$; see Fig.7 and note 12	58	64	–	dB
	intermodulation attenuation at 'yellow'	$f = 1.1 \text{ MHz}$; see Fig.7 and note 12	60	66	–	dB
$\alpha_{\text{IM}(3.3)}$	intermodulation attenuation at 'blue'	$f = 3.3 \text{ MHz}$; see Fig.7 and note 12	58	64	–	dB
	intermodulation attenuation at 'yellow'	$f = 3.3 \text{ MHz}$; see Fig.7 and note 12	59	65	–	dB

Multistandard VIF-PLL with QSS-IF and AM demodulator

TDA9810

SYMBOL	PARAMETER	CONDITIONS	MIN.	TYP.	MAX.	UNIT
$\alpha_{c(rms)}$	residual vision carrier (RMS value)	fundamental wave and harmonics; B/G and L standard	–	2	5	mV
$\Delta f_{unwanted(p-p)}$	robustness for unwanted frequency deviation of picture carrier (peak-to-peak value)	L standard; residual carrier: 3%; serration pulses: 50%; note 2	–	–	12	kHz
$\Delta\phi$	robustness for modulator imbalance	L standard; residual carrier: 0%; serration pulses: 50%; note 2	–	–	3	%
$\alpha_{H(sup)}$	suppression of video signal harmonics	note 8a	35	40	–	dB
$\alpha_{H(spur)}$	spurious elements	note 8b	40	–	–	dB
PSRR	power supply ripple rejection at pin 12	video signal; grey level; see Fig.12 B/G standard L standard	25 20	28 23	– –	dB dB
VIF-AGC detector (pin 21)						
$I_{ch(21)}$	charging current	B/G and L standard; note 10	0.75	1	1.25	mA
	additional charging current	L standard in event of missing VITS pulses and no white video content	1.9	2.5	3.1	μ A
	discharging current	B/G standard	15	20	25	μ A
		normal mode L standard	225	300	375	nA
	fast mode L standard	30	40	50	μ A	
$t_{resp(AGC)(r)}$	AGC response to a rising VIF step	B/G and L standard; note 13	–	0.05	0.1	ms/dB
$t_{resp(AGC)(f)}$	AGC response to a falling VIF step	B/G standard	–	2.2	3.5	ms/dB
		fast mode L standard	–	1.1	1.8	ms/dB
		normal mode L standard; note 13	–	150	240	ms/dB
ΔIF	VIF amplitude step for activating fast AGC mode	L standard	–2	–6	–10	dB
$V_{th(15)}$	threshold voltage level additional charging current	see Fig.9 L standard	–	1.95	–	V
		L standard; fast mode L	–	1.65	–	V

Multistandard VIF-PLL with QSS-IF and AM demodulator

TDA9810

SYMBOL	PARAMETER	CONDITIONS	MIN.	TYP.	MAX.	UNIT
Tuner AGC (pin 16)						
$V_{i(rms)}$	IF input signal voltage for minimum starting point of tuner takeover (RMS value)	input at pins 1 and 2; $R_{TOP} = 22 \text{ k}\Omega$; $I_{16} = 0.4 \text{ mA}$	–	2	5	mV
	IF input signal voltage for maximum starting point of tuner takeover (RMS value)	input at pins 1 and 2; $R_{TOP} = 0 \text{ }\Omega$; $I_{16} = 0.4 \text{ mA}$	50	100	–	mV
$V_{o(16)(max)}$	maximum output voltage	from external source; note 2	–	–	13.2	V
$V_{sat(16)}$	saturation voltage	$I_{16} = 1.5 \text{ mA}$	–	–	0.2	V
$\Delta V_{TOP(16)}/\Delta T$	variation of takeover point by temperature	$I_{16} = 0.4 \text{ mA}$	–	0.03	0.07	dB/K
$I_{sink(16)}$	sink current	see Fig.4 no tuner gain reduction; $V_{16} = 13.2 \text{ V}$	–	–	1	μA
		maximum tuner gain reduction	1.5	2	2.6	mA
ΔG_{IF}	IF slip by automatic gain control	tuner gain current from 20 to 80%	–	6	8	dB
AFC circuit (pin 17); see Fig.8 and note 14						
S	control steepness $\Delta I_{17}/\Delta f$	note 15	0.5	0.75	1.0	$\mu\text{A}/\text{kHz}$
$\Delta f_{IF}/\Delta T$	frequency variation by temperature	B/G and L standard; $I_{AFC} = 0$; note 4	–	–	$\pm 20 \times 10^{-6}$	K^{-1}
$V_{o(17)(max)}$	output voltage upper limit		$V_P - 0.6$	$V_P - 0.3$	–	V
$V_{o(17)(min)}$	output voltage lower limit		–	0.3	0.6	V
$I_{o(source)(17)}$	output source current		150	200	250	μA
$I_{o(sink)(17)}$	output sink current		150	200	250	μA
$\Delta I_{17(p-p)}$	residual video modulation current (peak-to-peak value)	B/G and L standard	–	20	30	μA

Multistandard VIF-PLL with QSS-IF and AM demodulator

TDA9810

SYMBOL	PARAMETER	CONDITIONS	MIN.	TYP.	MAX.	UNIT
Sound IF amplifier (pins 23 and 24)						
$V_{i(\text{SIF})}(\text{rms})$	input signal voltage sensitivity (RMS value)	FM mode; -3 dB at intercarrier output pin 10	-	30	70	μV
		AM mode; -3 dB at AF output pin 6	-	70	100	μV
$V_{i(\text{max})}(\text{rms})$	maximum input signal voltage (RMS value)	FM mode; +1 dB at intercarrier output pin 10	50	70	-	mV
		AM mode; +1 dB at AF output pin 6	80	140	-	mV
$G_{\text{cr}(\text{SIF})}$	SIF gain control range	FM and AM mode; see Fig.5	60	67	-	dB
$R_{i(\text{diff})}$	differential input resistance	note 2	1.7	2.2	2.7	k Ω
$C_{i(\text{diff})}$	differential input capacitance	note 2	1.2	1.7	2.5	pF
$V_{i(23,24)}$	DC input voltage		-	3.4	-	V
$\alpha_{\text{SIF,VIF}}$	crosstalk attenuation between SIF and VIF input	between pins 1 and 2 and pins 23 and 24; note 16	50	-	-	dB
SIF-AGC detector (pin 5)						
$I_{\text{ch}(5)}$	charging current	FM mode	8	12	16	μA
		AM mode	0.8	1.2	1.6	μA
$I_{\text{dch}(5)}$	discharging current	FM mode	8	12	16	μA
		normal mode AM	1	1.4	1.8	μA
		fast mode AM	60	85	110	μA
Single reference QSS intercarrier mixer (pin 10); note 17						
$V_{o(\text{intercarrier})}(\text{rms})$	IF intercarrier level (RMS value)	B/G standard; SC ₁ ; sound carrier 2 off	100	140	180	mV
		L standard; without modulation	100	140	180	mV
		NICAM	14	20	26	mV
B_{-3}	-3 dB intercarrier bandwidth	upper limit	7.5	9	-	MHz
$\alpha_{\text{c}(\text{rms})}$	residual sound carrier (RMS value)	fundamental wave and harmonics	-	2	-	mV
$R_{o(10)}$	output resistance	note 2	-	-	25	Ω
$V_{o(10)}$	DC output voltage		-	2.0	-	V
$I_{\text{bias}(\text{int})(10)}$	DC internal bias current for emitter-follower		1.5	1.9	-	mA
$I_{(\text{sink})(\text{max})10}$	maximum AC and DC output sink current		1.1	1.5	-	mA
$I_{(\text{source})(\text{max})10}$	maximum AC and DC output source current		3.0	3.5	-	mA

Multistandard VIF-PLL with QSS-IF and AM demodulator

TDA9810

SYMBOL	PARAMETER	CONDITIONS	MIN.	TYP.	MAX.	UNIT
Single reference QSS AF performance for FM operation (B/G standard); notes 18 to 21; see Table 1						
S/N _{W(SC1)}	weighted signal-to-noise ratio for SC ₁	PC/SC ₁ ratio at pins 1 and 2; 27 kHz (54% FM deviation); "CCIR 468-4"	40	–	–	dB
		black picture	53	58	–	dB
		white picture	52	55	–	dB
		6 kHz sine wave (black to white modulation)	44	48	–	dB
		250 kHz square wave (black to white modulation)	40	45	–	dB
		sound carrier subharmonics; f = 2.75 MHz ±3 kHz	45	51	–	dB
		sound carrier subharmonics; f = 2.87 MHz ±3 kHz	46	52	–	dB
S/N _{W(SC2)}	weighted signal-to-noise ratio for SC ₂	PC/SC ₂ ratio at pins 1 and 2; 27 kHz (54% FM deviation); "CCIR 468-4"	40	–	–	dB
		black picture	48	55	–	dB
		white picture	46	52	–	dB
		6 kHz sine wave (black to white modulation)	42	46	–	dB
		250 kHz square wave (black to white modulation)	29	34	–	dB
		sound carrier subharmonics; f = 2.75 MHz ±3 kHz	44	50	–	dB
		sound carrier subharmonics; f = 2.87 MHz ±3 kHz	45	51	–	dB
AM operation (L standard; pin 6); note 22						
V _{o(AF)(rms)}	AF output signal voltage (RMS value)	54% modulation	400	500	600	mV
THD	total harmonic distortion	54% modulation; see Fig.11	–	0.5	1.0	%
B ₋₃	–3 dB AF bandwidth		100	125	–	kHz
S/N _W	weighted signal-to-noise ratio	"CCIR 468-4"; see Fig.10	47	53	–	dB
V ₆	DC potential voltage	tracked with supply voltage	–	2.5	–	V
PSRR	power supply ripple rejection	see Fig.12	22	25	–	dB

Multistandard VIF-PLL with QSS-IF and AM demodulator

TDA9810

SYMBOL	PARAMETER	CONDITIONS	MIN.	TYP.	MAX.	UNIT
AM mute switch (pin 11)						
V ₁₁	DC potential	note 23	2.8	–	V _P	V
	input voltage for no mute					
	input voltage for mute		0	–	0.8	V
I _{IL}	LOW level input current	V ₁₁ = 0 V	175	250	325	μA
L/L accent gating switch (pin 14)						
V ₁₄	DC potential voltage for	note 23	2.8	–	V _P	V
	gating on					
	gating off		0	–	2.0	V
I _{IL}	LOW level input current	V ₁₄ = 0 V	140	200	260	μA

Notes

- Values of video and sound parameters are decreased at V_P = 4.5 V.
- This parameter is not tested during production and is only given as application information for designing the television receiver.
- Loop bandwidth BL = 70 kHz (natural frequency f_n = 12 kHz; damping factor d ≈ 3; calculated for peak level). Resonance circuit of VCO: Q₀ > 50; C_{ext} = 8.2 pF ± 0.25 pF; C_{int} ≈ 8.5 pF (loop voltage ≈ 2.7 V).
- Temperature coefficient of external LC-circuit is equal to zero.
- V_{i(IF)(rms)} = 10 mV; Δf = 1 MHz (VCO frequency offset related to picture carrier frequency); white picture video modulation.
- V_{i(IF)} signal for nominal video signal.
- Offset current measured between pin 4 and half of supply voltage (V_P = 2.5 V) under the following conditions: no input signal at VIF input (pins 1 and 2) and VIF amplifier gain at minimum (V₂₁ = V_P). Due to sample-and-hold mode of the FPLL in L standard, the leakage current of the loop filter capacitor (C = 220 nF) should not exceed 500 nA.
- Measurements taken with SAW filter K6257 (sound carrier suppression: 40 dB); loop bandwidth = 70 kHz.
 - Modulation VSB; sound carrier **off**; f_{video} > 0.5 MHz.
 - Sound carrier **on**; SIF SAW filter K9453; f_{video} = 10 kHz to 10 MHz.
- The 7 dB buffer gain accounts for 1 dB loss in the sound trap. Buffer output signal is typically 2 V (p-p), in event of CVBS video amplifier output typical 1 V (p-p). If no sound trap is applied a 330 Ω resistor must be connected from output to input (from pin 9 to pin 13).
- The leakage current of the AGC capacitor should not exceed 1 μA at B/G standard respectively 10 nA current at L standard. Larger currents will increase the tilt.
- S/N is the ratio of black-to-white amplitude to the black level noise voltage (RMS value, pin 12). B = 5 MHz weighted in accordance with "CCIR 567".
- The intermodulation figures are defined:

$$\alpha_{IM(1.1)} = 20 \log \left(\frac{V_0 \text{ at } 4.4 \text{ MHz}}{V_0 \text{ at } 1.1 \text{ MHz}} \right) + 3.6 \text{ dB}; \alpha_{IM(1.1)} \text{ value at } 1.1 \text{ MHz referenced to black/white signal};$$

$$\alpha_{IM(3.3)} = 20 \log \left(\frac{V_0 \text{ at } 4.4 \text{ MHz}}{V_0 \text{ at } 3.3 \text{ MHz}} \right); \alpha_{IM(3.3)} \text{ value at } 3.3 \text{ MHz referenced to colour carrier}.$$
- Response speed valid for a VIF input level range of 200 μV up to 70 mV.
- To match the AFC output signal to different tuning systems a current source output is provided. The test circuit is given in Fig.8. The AFC-steepness can be changed by the resistors at pin 17.

Multistandard VIF-PLL with QSS-IF and AM demodulator

TDA9810

15. Depending on the ratio $\Delta C/C_0$ of the LC resonant circuit of VCO ($Q_0 > 50$; see note 3; $C_0 = C_{int} + C_{ext}$).
16. Source impedance: 2.3 k Ω in parallel to 12 pF (SAW filter); $f_{IF} = 38.9$ MHz.
17. For picture to sound carrier ratio see Table 1. The NICAM L subcarrier is 17 dB lower than the AM sound carrier and depends on its AM modulation.
18. The V_{oQSS} output (pin 10) is analysed by a test demodulator TDA9820. The S/N ratio of this IC is more than 60 dB, related to a deviation of ± 27 kHz, in accordance with "CCIR 468-4".
19. For all S/N measurements the used vision IF modulator has to meet the following specifications:
 - a) Incidental phase modulation for black-to-white jump less than 0.5 degrees.
 - b) QSS AF performance, measured with the television-demodulator AMF2 (audio output, weighted S/N ratio) better than 60 dB (deviation ± 27 kHz) for 6 kHz sine wave black-to-white video modulation.
 - c) Picture-to-sound carrier ratio; PC/SC₁ = 13 dB; (transmitter).
20. Measurements taken with SAW filter K6257 (Siemens) for vision IF (suppressed sound carrier) and K9453 (Siemens) for sound IF (suppressed picture carrier). Input level $V_{i(SIF)(rms)} = 10$ mV, 27 kHz (54% FM deviation).
21. The PC/SC ratio at pins 1 and 2 is calculated as the addition of TV transmitter PC/SC ratio and SAW filter PC/SC ratio. This PC/SC ratio is necessary to achieve the S/N_W values as noted. A different PC/SC ratio will change these values.
22. Measurements taken with SAW filter K9453 (Siemens) for AM sound IF (suppressed picture carrier).
23. The input voltage has to be $V_i > 2.8$ V, or open-circuit.

Table 1 Input frequencies and carrier ratios

DESCRIPTION	SYMBOL	B/G STANDARD	L STANDARD	L ACCENT STANDARD	NICAM L	UNIT
Picture carrier	f_{pc}	38.9	38.9	33.9	38.9	MHz
Sound carrier	f_{sc1}	33.4	32.4	40.4	32.4	MHz
	$f_{sc2/NICAM}$	33.158	–	–	32.05	MHz
Picture to sound carrier ratio	PC/SC ₁	13	10	10	10	dB
	PC/SC _{2/NICAM}	20	–	–	27	dB

Table 2 Switch logic

STANDARD SWITCH (PIN 8)	SELECTED STANDARD	VIDEO POLARITY	FM-PLL		AF-AMPLIFIER	
			1	2	1	2
2.8 V to V_P	B/G	negative	on	on	FM	FM
1.3 to 2.3 V	B/G, with external VIF AGC	negative	on	on	FM	FM
0 to 0.8 V	L	positive	off	off	AM	mute

Multistandard VIF-PLL with QSS-IF and AM demodulator

TDA9810

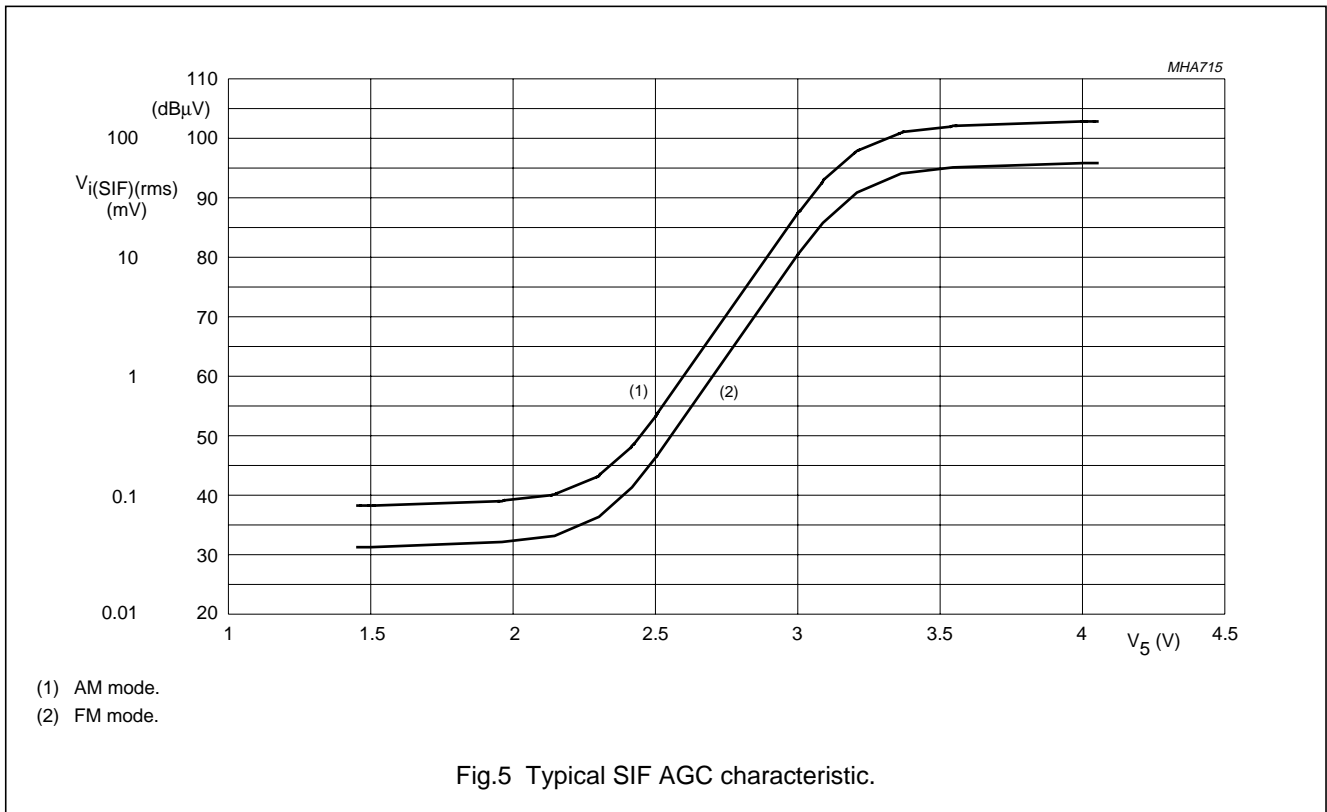
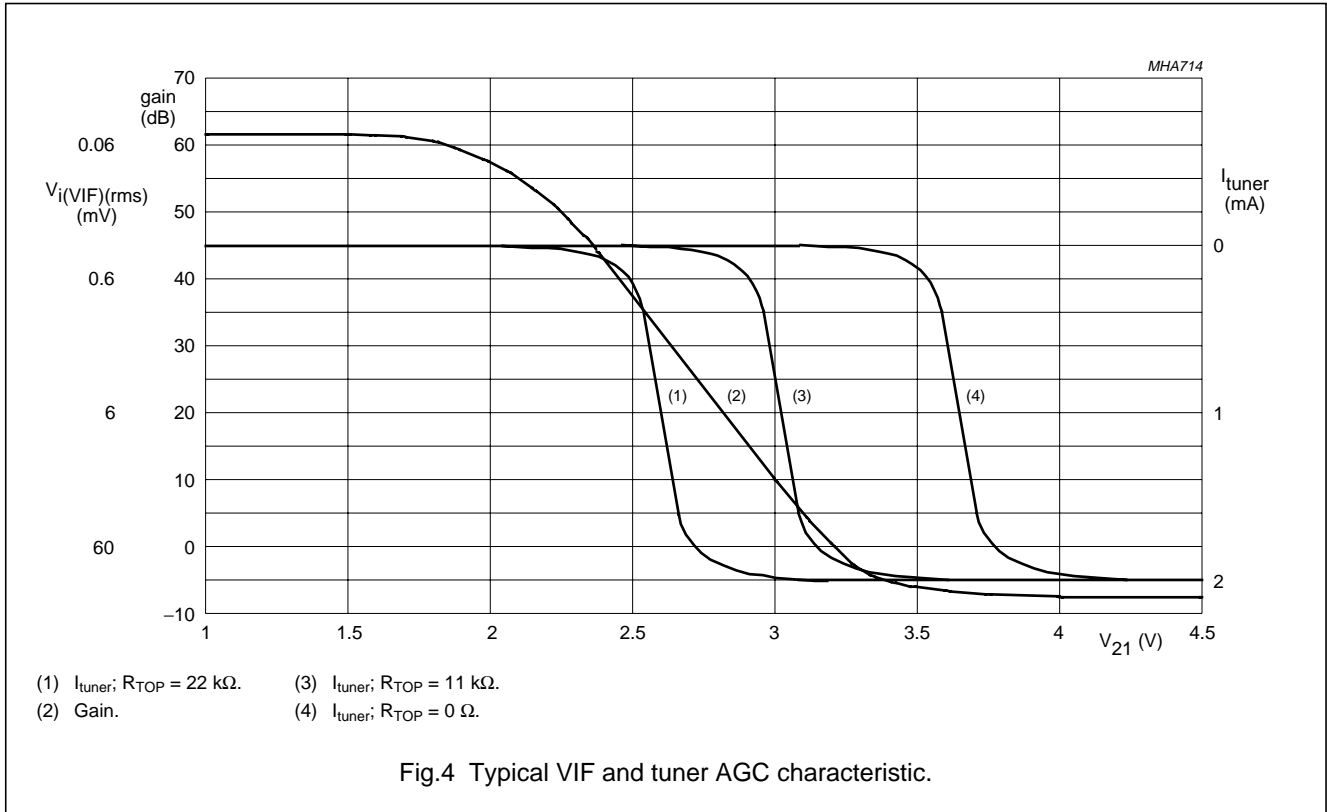

Multistandard VIF-PLL with QSS-IF and AM demodulator

TDA9810

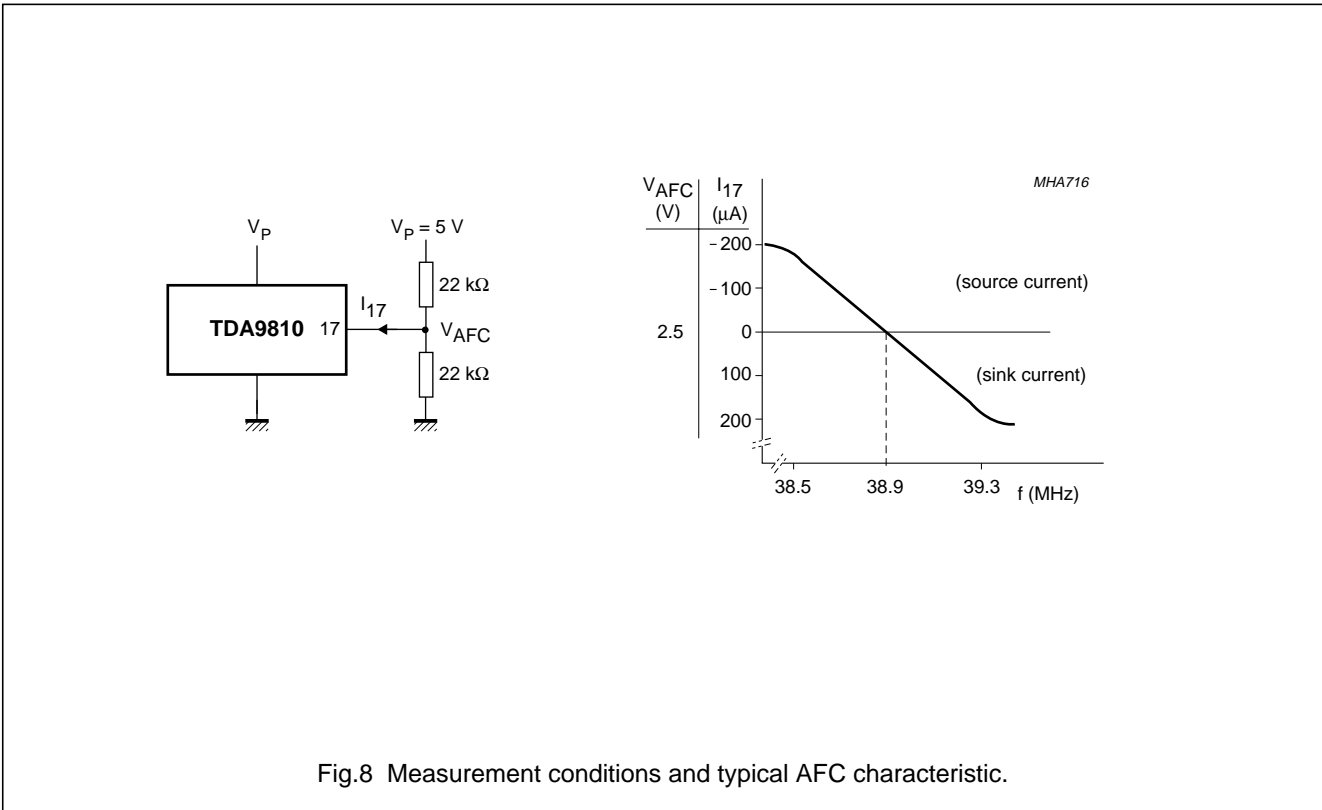
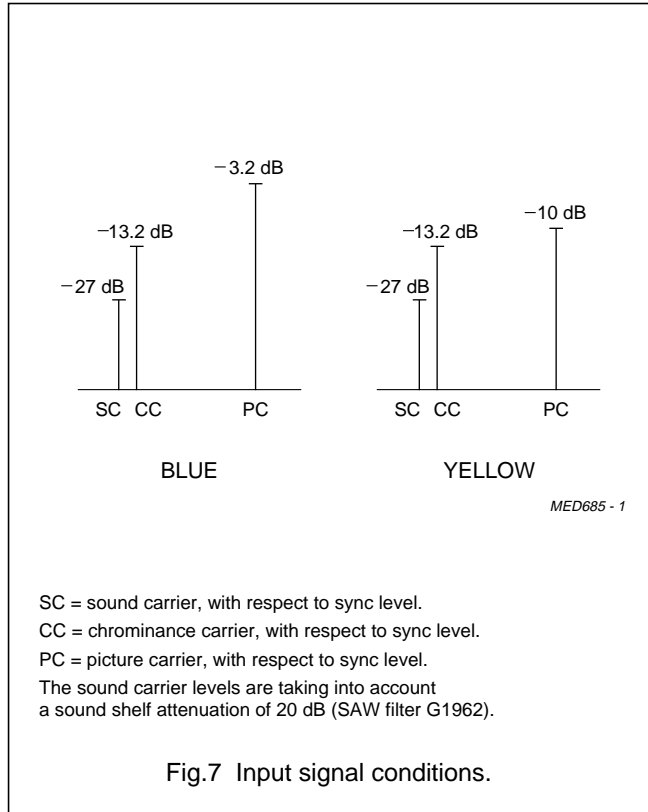
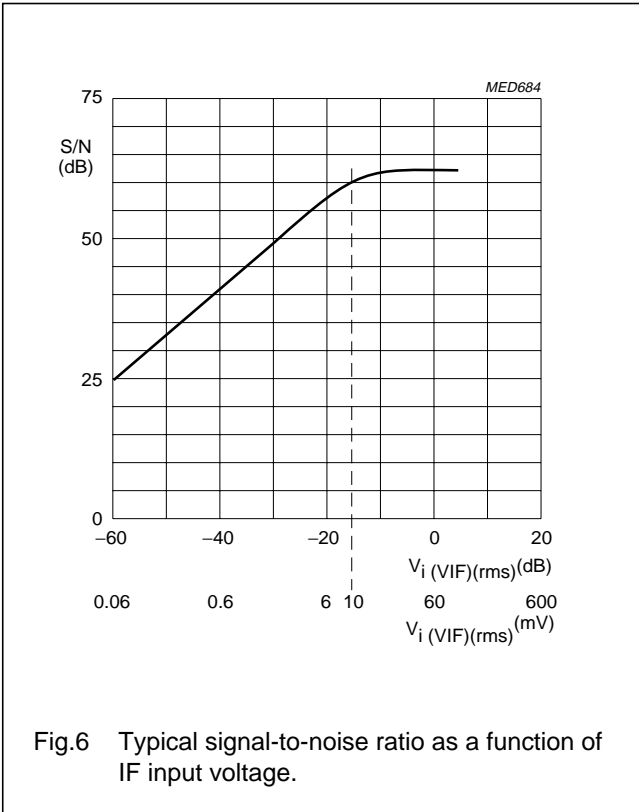

Multistandard VIF-PLL with QSS-IF and AM demodulator

TDA9810

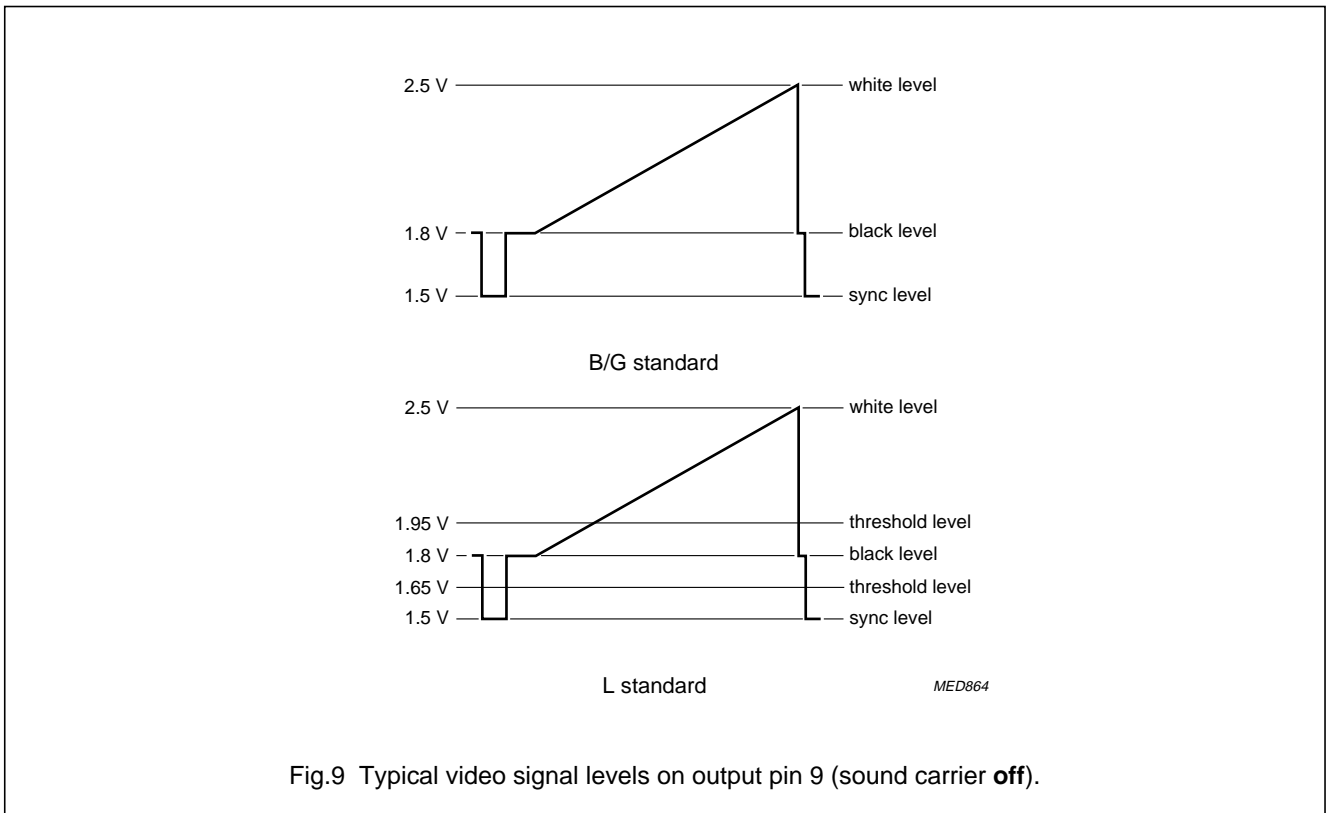

Fig.9 Typical video signal levels on output pin 9 (sound carrier off).

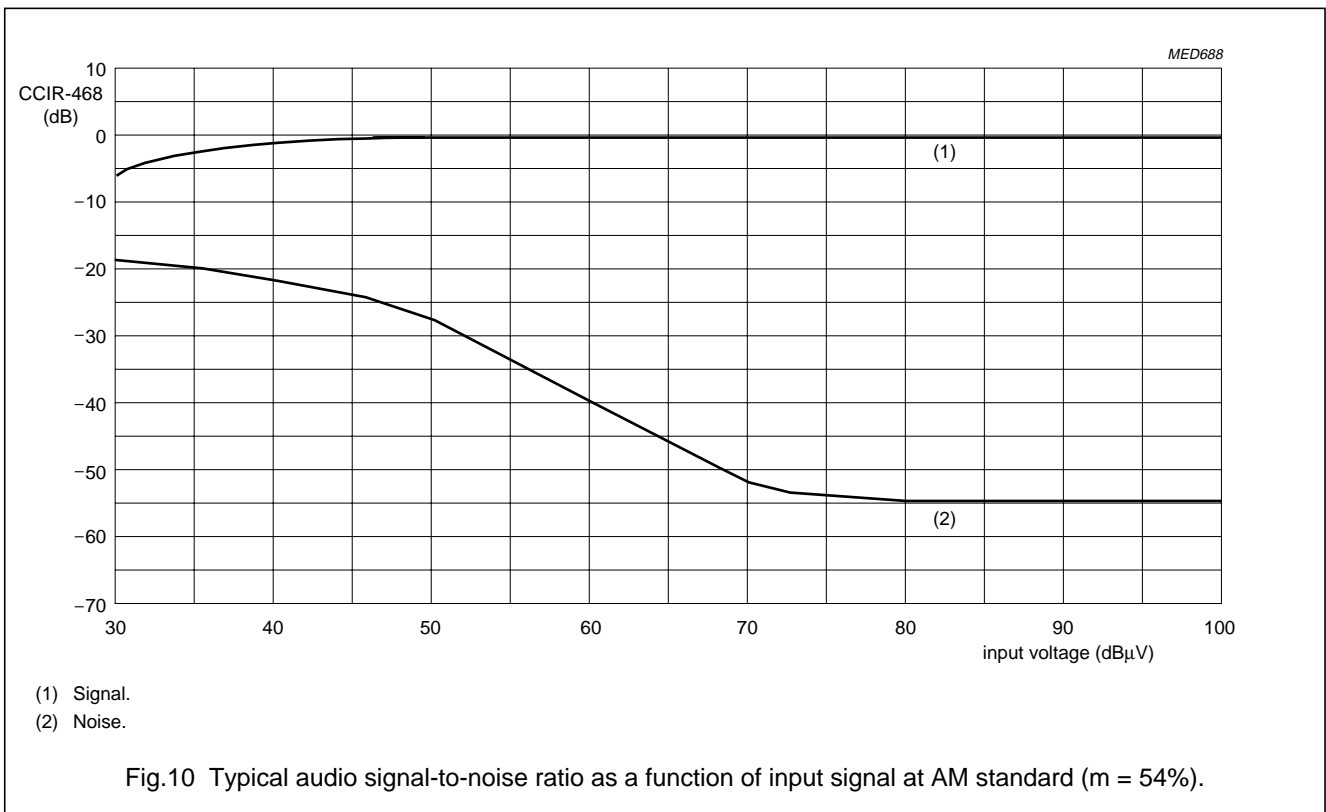
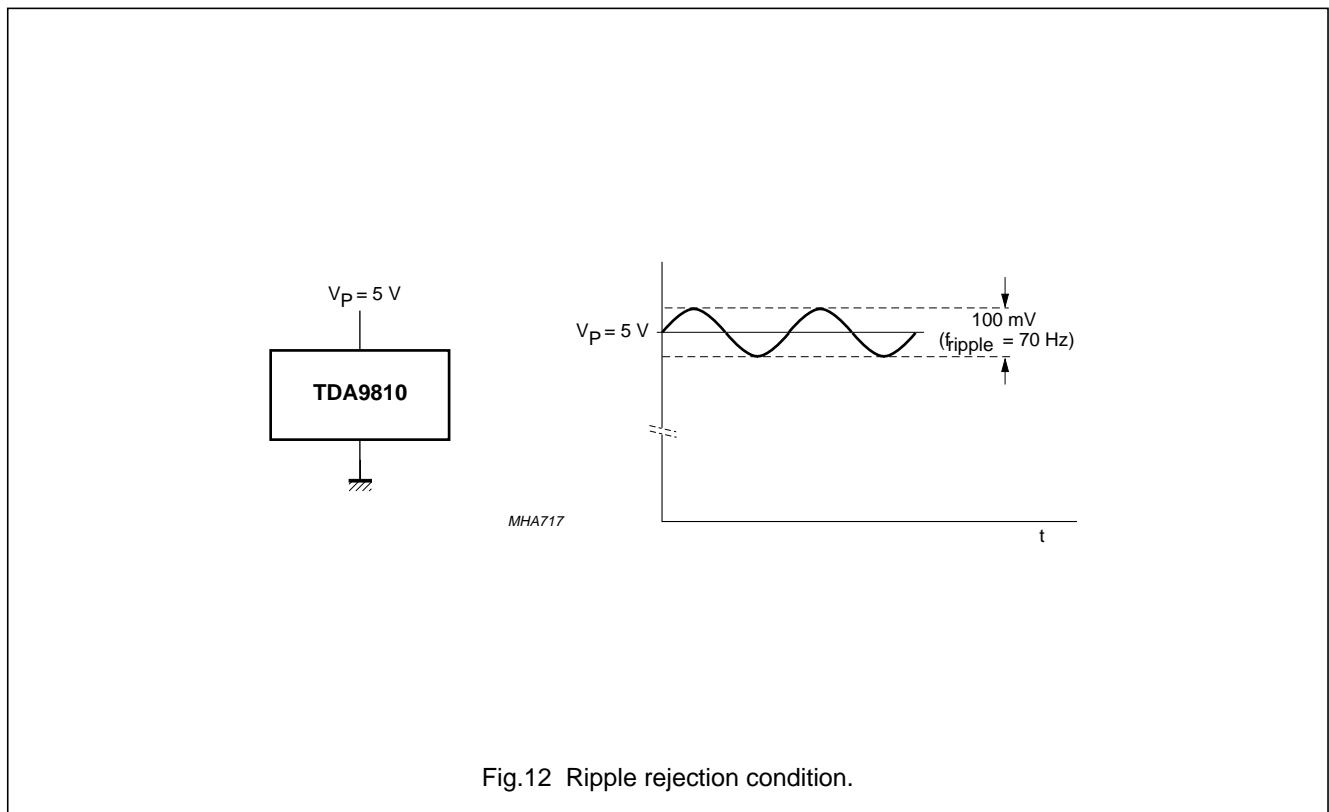
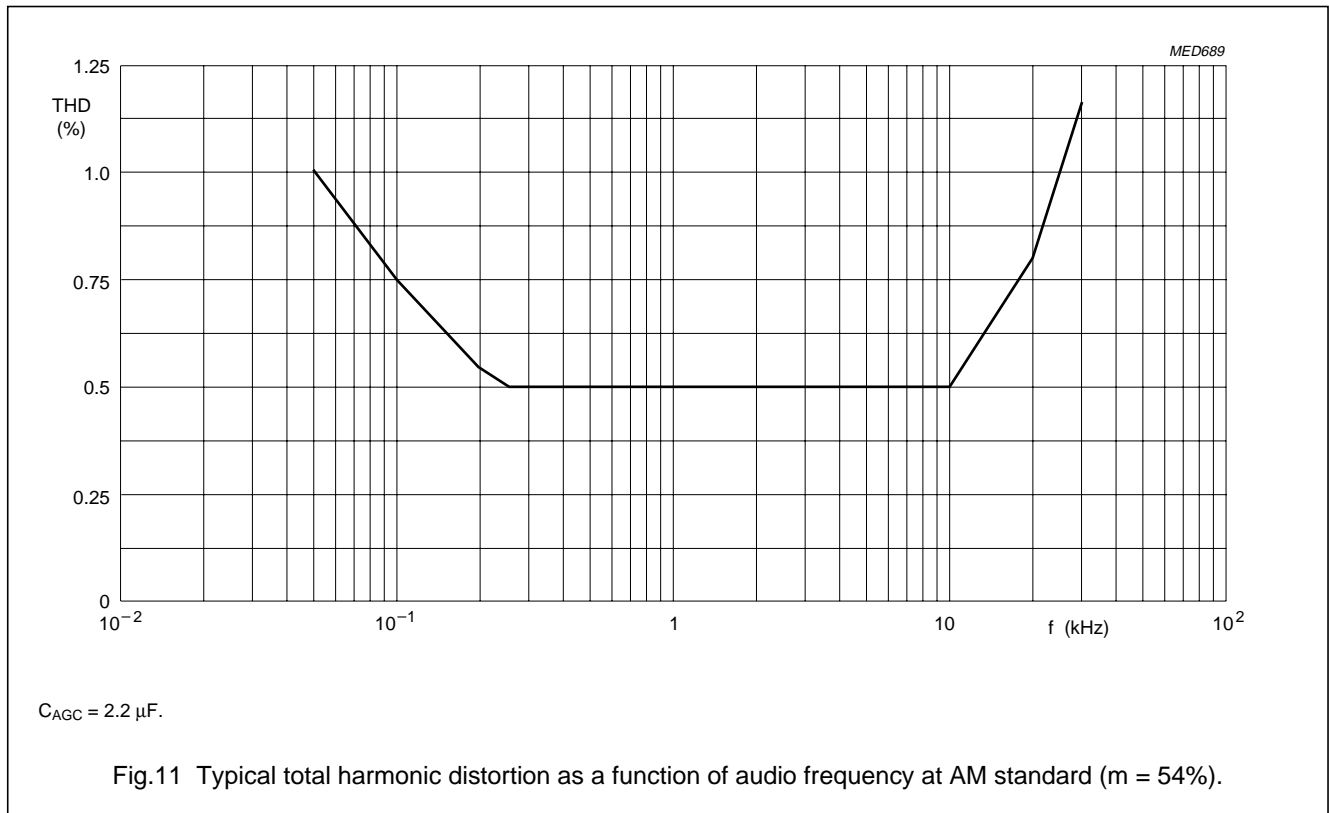

Fig.10 Typical audio signal-to-noise ratio as a function of input signal at AM standard (m = 54%).

Multistandard VIF-PLL with QSS-IF and AM demodulator

TDA9810



Multistandard VIF-PLL with QSS-IF and AM demodulator

TDA9810

INTERNAL PIN CONFIGURATION

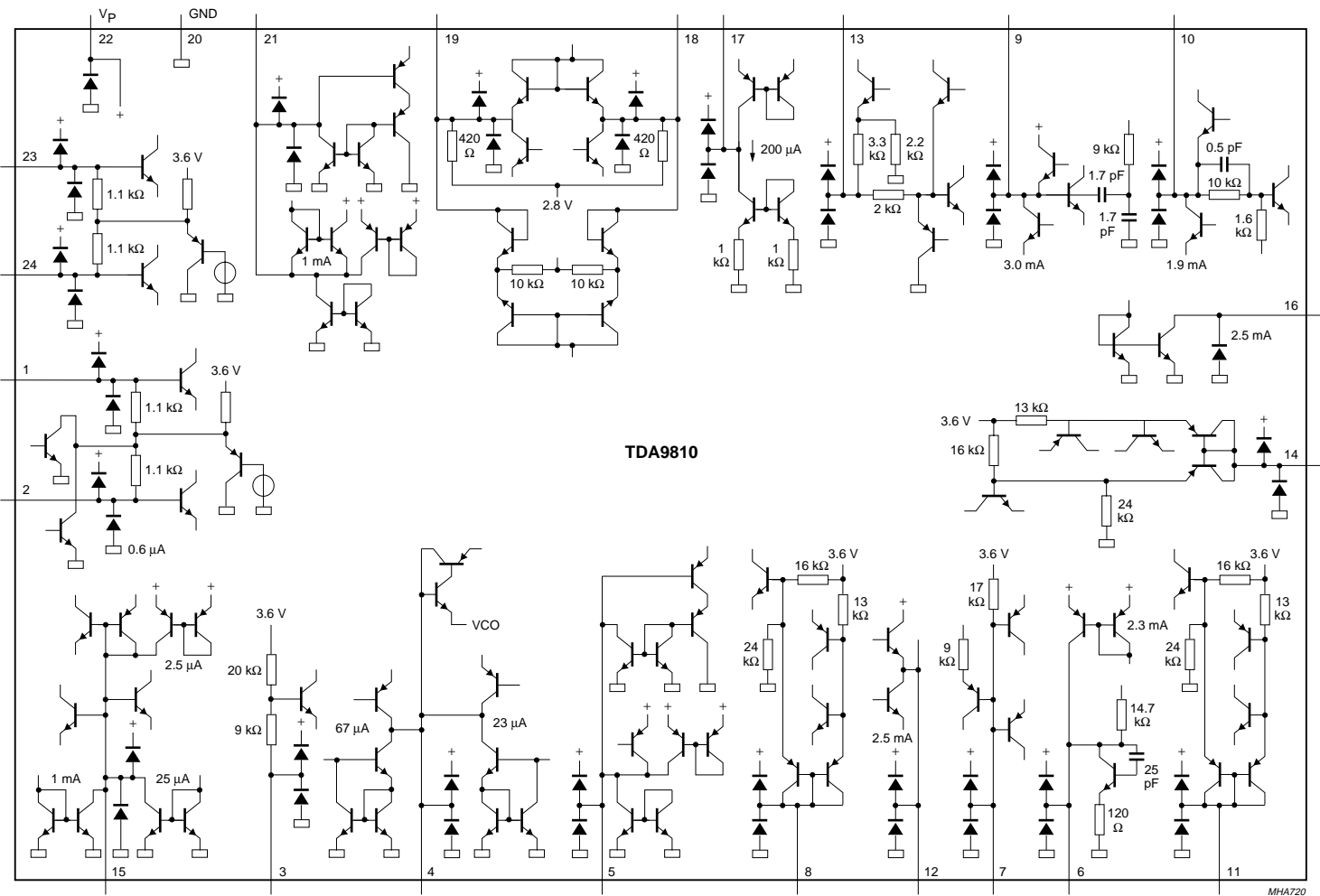
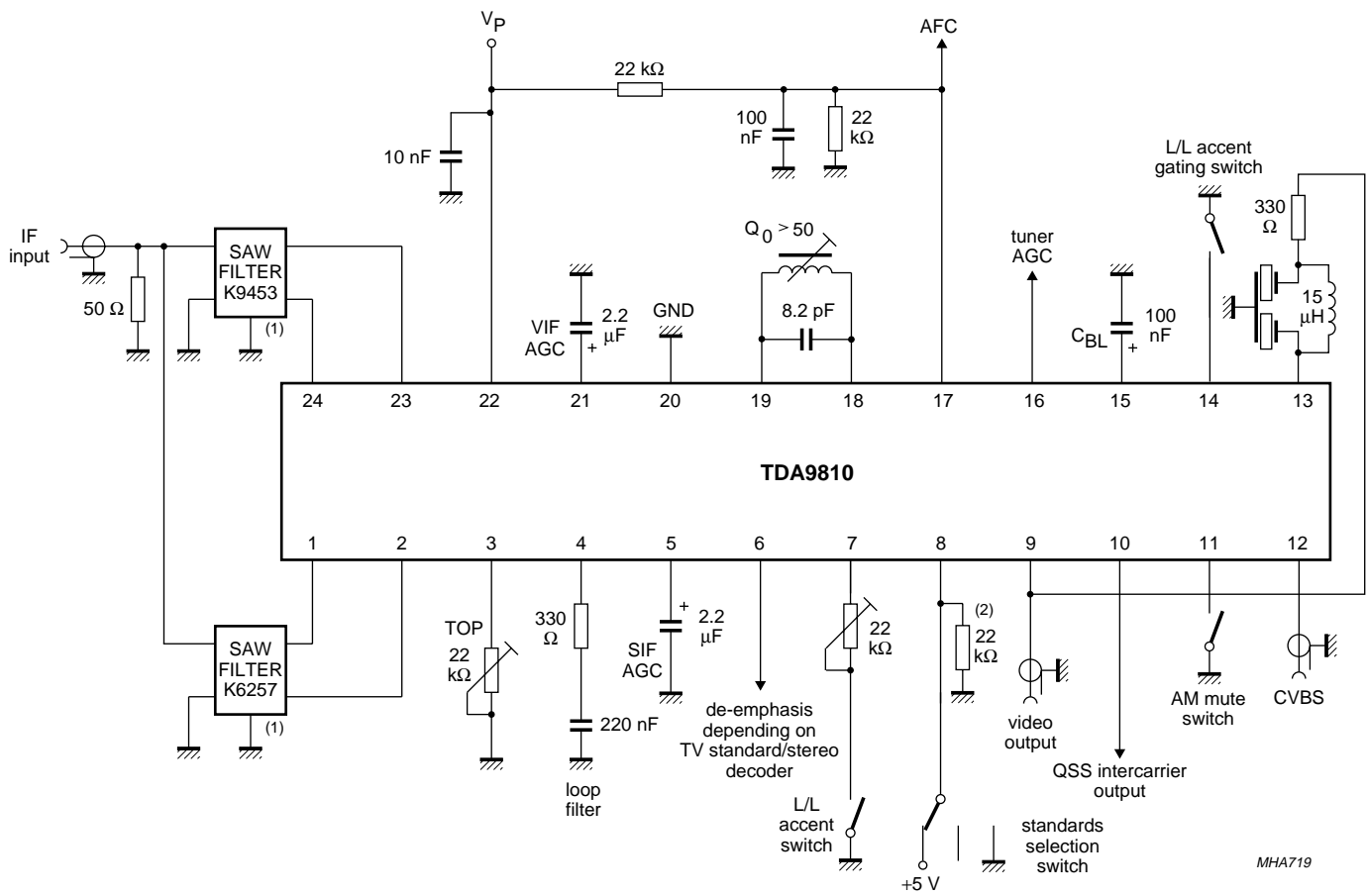

Fig.13 Internal pin configuration.

MHA720

Multistandard VIF-PLL with QSS-IF and AM demodulator

TDA9810



MHA719

(1) Depends on standard.
 (2) Only required for external AGC mode.

Fig.15 Application circuit.

Multistandard VIF-PLL with QSS-IF and AM demodulator

TDA9810

PACKAGE OUTLINES

SDIP24: plastic shrink dual in-line package; 24 leads (400 mil)

SOT234-1

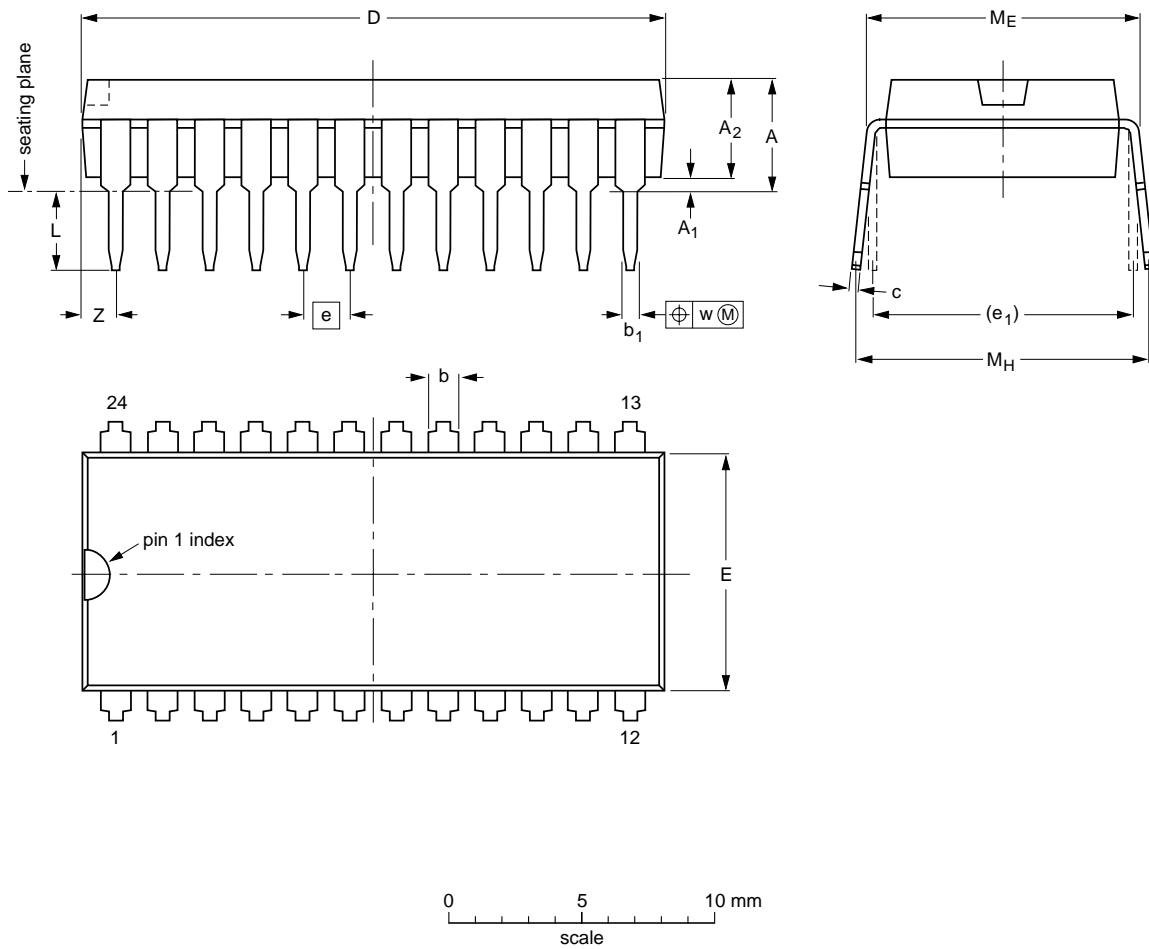

DIMENSIONS (mm are the original dimensions)

UNIT	A max.	A ₁ min.	A ₂ max.	b	b ₁	c	D ⁽¹⁾	E ⁽¹⁾	e	e ₁	L	M _E	M _H	w	Z ⁽¹⁾ max.
mm	4.7	0.51	3.8	1.3 0.8	0.53 0.40	0.32 0.23	22.3 21.4	9.1 8.7	1.778	10.16	3.2 2.8	10.7 10.2	12.2 10.5	0.18	1.6

Note

1. Plastic or metal protrusions of 0.25 mm maximum per side are not included.

OUTLINE VERSION	REFERENCES				EUROPEAN PROJECTION	ISSUE DATE
	IEC	JEDEC	EIAJ			
SOT234-1						92-11-17 95-02-04

Multistandard VIF-PLL with QSS-IF and AM demodulator

TDA9810

SO24: plastic small outline package; 24 leads; body width 7.5 mm

SOT137-1

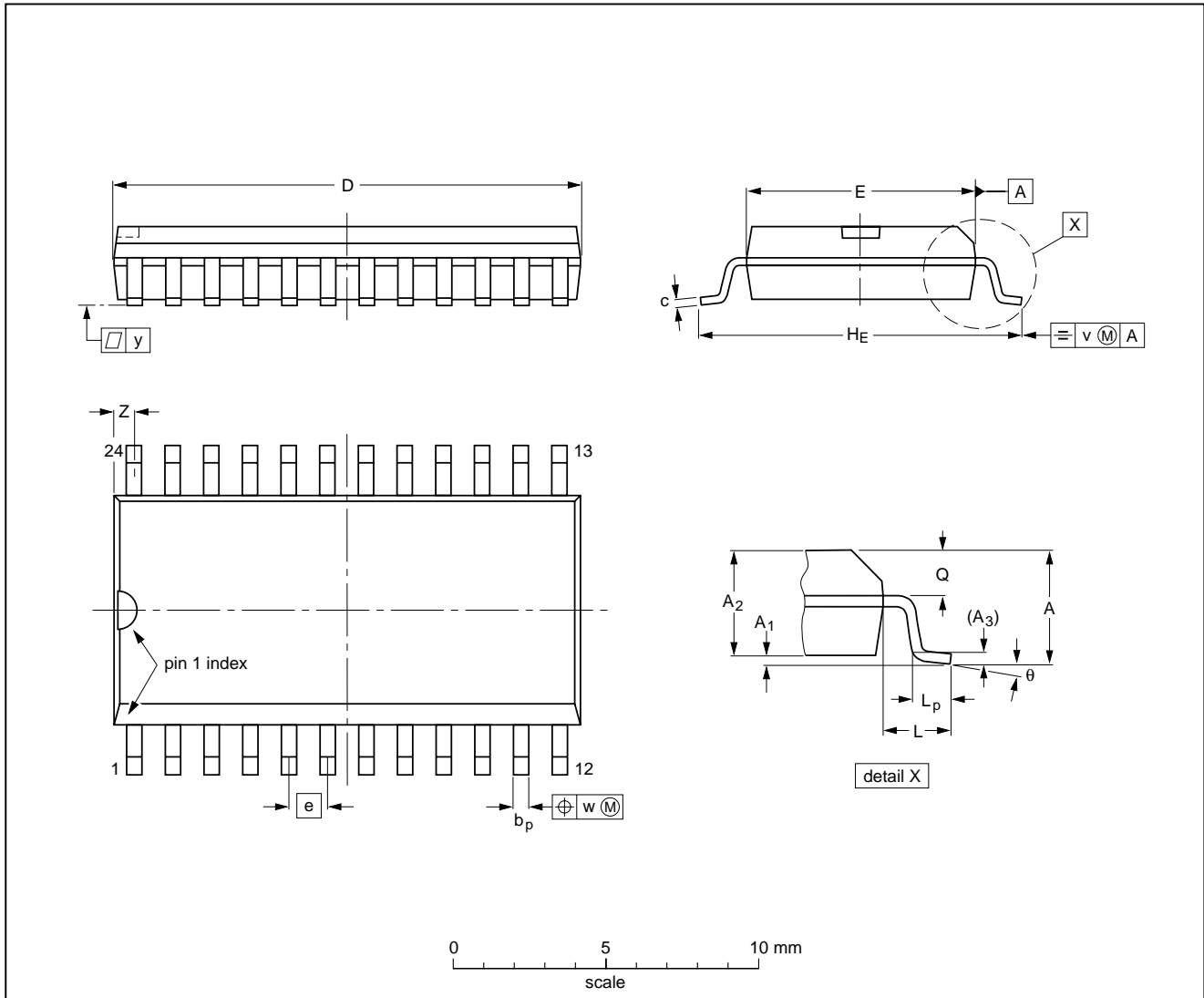

DIMENSIONS (inch dimensions are derived from the original mm dimensions)

UNIT	A max.	A ₁	A ₂	A ₃	b _p	c	D ⁽¹⁾	E ⁽¹⁾	e	H _E	L	L _p	Q	v	w	y	Z ⁽¹⁾	θ
mm	2.65	0.30 0.10	2.45 2.25	0.25	0.49 0.36	0.32 0.23	15.6 15.2	7.6 7.4	1.27	10.65 10.00	1.4	1.1 0.4	1.1 1.0	0.25	0.25	0.1	0.9 0.4	8° 0°
inches	0.10	0.012 0.004	0.096 0.089	0.01	0.019 0.014	0.013 0.009	0.61 0.60	0.30 0.29	0.050	0.419 0.394	0.055	0.043 0.016	0.043 0.039	0.01	0.01	0.004	0.035 0.016	

Note

1. Plastic or metal protrusions of 0.15 mm maximum per side are not included.

OUTLINE VERSION	REFERENCES			EUROPEAN PROJECTION	ISSUE DATE
	IEC	JEDEC	EIAJ		
SOT137-1	075E05	MS-013AD			95-01-24 97-05-22

Multistandard VIF-PLL with QSS-IF and AM demodulator

TDA9810

SOLDERING

Introduction

This text gives a very brief insight to a complex technology. A more in-depth account of soldering ICs can be found in our "Data Handbook IC26; Integrated Circuit Packages" (document order number 9398 652 90011).

There is no soldering method that is ideal for all IC packages. Wave soldering is often preferred when through-hole and surface mount components are mixed on one printed-circuit board. However, wave soldering is not always suitable for surface mount ICs, or for printed-circuit boards with high population densities. In these situations reflow soldering is often used.

Through-hole mount packages

SOLDERING BY DIPPING OR BY SOLDER WAVE

The maximum permissible temperature of the solder is 260 °C; solder at this temperature must not be in contact with the joints for more than 5 seconds. The total contact time of successive solder waves must not exceed 5 seconds.

The device may be mounted up to the seating plane, but the temperature of the plastic body must not exceed the specified maximum storage temperature ($T_{stg(max)}$). If the printed-circuit board has been pre-heated, forced cooling may be necessary immediately after soldering to keep the temperature within the permissible limit.

MANUAL SOLDERING

Apply the soldering iron (24 V or less) to the lead(s) of the package, either below the seating plane or not more than 2 mm above it. If the temperature of the soldering iron bit is less than 300 °C it may remain in contact for up to 10 seconds. If the bit temperature is between 300 and 400 °C, contact may be up to 5 seconds.

Surface mount packages

REFLOW SOLDERING

Reflow soldering requires solder paste (a suspension of fine solder particles, flux and binding agent) to be applied to the printed-circuit board by screen printing, stencilling or pressure-syringe dispensing before package placement.

Several methods exist for reflowing; for example, infrared/convection heating in a conveyor type oven. Throughput times (preheating, soldering and cooling) vary between 100 and 200 seconds depending on heating method.

Typical reflow peak temperatures range from 215 to 250 °C. The top-surface temperature of the packages should preferably be kept below 230 °C.

WAVE SOLDERING

Conventional single wave soldering is not recommended for surface mount devices (SMDs) or printed-circuit boards with a high component density, as solder bridging and non-wetting can present major problems.

To overcome these problems the double-wave soldering method was specifically developed.

If wave soldering is used the following conditions must be observed for optimal results:

- Use a double-wave soldering method comprising a turbulent wave with high upward pressure followed by a smooth laminar wave.
- For packages with leads on two sides and a pitch (e):
 - larger than or equal to 1.27 mm, the footprint longitudinal axis is **preferred** to be parallel to the transport direction of the printed-circuit board;
 - smaller than 1.27 mm, the footprint longitudinal axis **must** be parallel to the transport direction of the printed-circuit board.

The footprint must incorporate solder thieves at the downstream end.

- For packages with leads on four sides, the footprint must be placed at a 45° angle to the transport direction of the printed-circuit board. The footprint must incorporate solder thieves downstream and at the side corners.

During placement and before soldering, the package must be fixed with a droplet of adhesive. The adhesive can be applied by screen printing, pin transfer or syringe dispensing. The package can be soldered after the adhesive is cured.

Typical dwell time is 4 seconds at 250 °C.

A mildly-activated flux will eliminate the need for removal of corrosive residues in most applications.

MANUAL SOLDERING

Fix the component by first soldering two diagonally-opposite end leads. Use a low voltage (24 V or less) soldering iron applied to the flat part of the lead. Contact time must be limited to 10 seconds at up to 300 °C.

When using a dedicated tool, all other leads can be soldered in one operation within 2 to 5 seconds between 270 and 320 °C.

Multistandard VIF-PLL with QSS-IF and AM demodulator

TDA9810

Suitability of IC packages for wave, reflow and dipping soldering methods

MOUNTING	PACKAGE	SOLDERING METHOD		
		WAVE	REFLOW ⁽¹⁾	DIPPING
Through-hole mount	DBS, DIP, HDIP, SDIP, SIL	suitable ⁽²⁾	–	suitable
Surface mount	BGA, SQFP	not suitable	suitable	–
	HLQFP, HSQFP, HSOP, HTSSOP, SMS	not suitable ⁽³⁾	suitable	–
	PLCC ⁽⁴⁾ , SO, SOJ	suitable	suitable	–
	LQFP, QFP, TQFP	not recommended ⁽⁴⁾⁽⁵⁾	suitable	–
	SSOP, TSSOP, VSO	not recommended ⁽⁶⁾	suitable	–

Notes

- All surface mount (SMD) packages are moisture sensitive. Depending upon the moisture content, the maximum temperature (with respect to time) and body size of the package, there is a risk that internal or external package cracks may occur due to vaporization of the moisture in them (the so called popcorn effect). For details, refer to the Drypack information in the *"Data Handbook IC26; Integrated Circuit Packages; Section: Packing Methods"*.
- For SDIP packages, the longitudinal axis must be parallel to the transport direction of the printed-circuit board.
- These packages are not suitable for wave soldering as a solder joint between the printed-circuit board and heatsink (at bottom version) can not be achieved, and as solder may stick to the heatsink (on top version).
- If wave soldering is considered, then the package must be placed at a 45° angle to the solder wave direction. The package footprint must incorporate solder thieves downstream and at the side corners.
- Wave soldering is only suitable for LQFP, QFP and TQFP packages with a pitch (e) equal to or larger than 0.8 mm; it is definitely not suitable for packages with a pitch (e) equal to or smaller than 0.65 mm.
- Wave soldering is only suitable for SSOP and TSSOP packages with a pitch (e) equal to or larger than 0.65 mm; it is definitely not suitable for packages with a pitch (e) equal to or smaller than 0.5 mm.

DEFINITIONS

Data sheet status	
Objective specification	This data sheet contains target or goal specifications for product development.
Preliminary specification	This data sheet contains preliminary data; supplementary data may be published later.
Product specification	This data sheet contains final product specifications.
Limiting values	
Limiting values given are in accordance with the Absolute Maximum Rating System (IEC 134). Stress above one or more of the limiting values may cause permanent damage to the device. These are stress ratings only and operation of the device at these or at any other conditions above those given in the Characteristics sections of the specification is not implied. Exposure to limiting values for extended periods may affect device reliability.	
Application information	
Where application information is given, it is advisory and does not form part of the specification.	

LIFE SUPPORT APPLICATIONS

These products are not designed for use in life support appliances, devices, or systems where malfunction of these products can reasonably be expected to result in personal injury. Philips customers using or selling these products for use in such applications do so at their own risk and agree to fully indemnify Philips for any damages resulting from such improper use or sale.

Multistandard VIF-PLL with QSS-IF and
AM demodulator

TDA9810

NOTES

Multistandard VIF-PLL with QSS-IF and
AM demodulator

TDA9810

NOTES

Multistandard VIF-PLL with QSS-IF and
AM demodulator

TDA9810

NOTES

Philips Semiconductors – a worldwide company

Argentina: see South America

Australia: 34 Waterloo Road, NORTH RYDE, NSW 2113,
Tel. +61 2 9805 4455, Fax. +61 2 9805 4466

Austria: Computerstr. 6, A-1101 WIEN, P.O. Box 213,
Tel. +43 1 60 101 1248, Fax. +43 1 60 101 1210

Belarus: Hotel Minsk Business Center, Bld. 3, r. 1211, Volodarski Str. 6,
220050 MINSK, Tel. +375 172 20 0733, Fax. +375 172 20 0773

Belgium: see The Netherlands

Brazil: see South America

Bulgaria: Philips Bulgaria Ltd., Energoproject, 15th floor,
51 James Bourchier Blvd., 1407 SOFIA,
Tel. +359 2 68 9211, Fax. +359 2 68 9102

Canada: PHILIPS SEMICONDUCTORS/COMPONENTS,
Tel. +1 800 234 7381, Fax. +1 800 943 0087

China/Hong Kong: 501 Hong Kong Industrial Technology Centre,
72 Tat Chee Avenue, Kowloon Tong, HONG KONG,
Tel. +852 2319 7888, Fax. +852 2319 7700

Colombia: see South America

Czech Republic: see Austria

Denmark: Sydhavnsgade 23, 1780 COPENHAGEN V,
Tel. +45 33 29 3333, Fax. +45 33 29 3905

Finland: Sinikalliontie 3, FIN-02630 ESPOO,
Tel. +358 9 615 800, Fax. +358 9 6158 0920

France: 51 Rue Carnot, BP317, 92156 SURESNES Cedex,
Tel. +33 1 4099 6161, Fax. +33 1 4099 6427

Germany: Hammerbrookstraße 69, D-20097 HAMBURG,
Tel. +49 40 2353 60, Fax. +49 40 2353 6300

Hungary: see Austria

India: Philips INDIA Ltd, Band Box Building, 2nd floor,
254-D, Dr. Annie Besant Road, Worli, MUMBAI 400 025,
Tel. +91 22 493 8541, Fax. +91 22 493 0966

Indonesia: PT Philips Development Corporation, Semiconductors Division,
Gedung Philips, Jl. Buncit Raya Kav.99-100, JAKARTA 12510,
Tel. +62 21 794 0040 ext. 2501, Fax. +62 21 794 0080

Ireland: Newstead, Clonskeagh, DUBLIN 14,
Tel. +353 1 7640 000, Fax. +353 1 7640 200

Israel: RAPAC Electronics, 7 Kehilat Saloniki St, PO Box 18053,
TEL AVIV 61180, Tel. +972 3 645 0444, Fax. +972 3 649 1007

Italy: PHILIPS SEMICONDUCTORS, Piazza IV Novembre 3,
20124 MILANO, Tel. +39 02 67 52 2531, Fax. +39 02 67 52 2557

Japan: Philips Bldg 13-37, Kohnan 2-chome, Minato-ku,
TOKYO 108-8507, Tel. +81 3 3740 5130, Fax. +81 3 3740 5077

Korea: Philips House, 260-199 Itaewon-dong, Yongsan-ku, SEOUL,
Tel. +82 2 709 1412, Fax. +82 2 709 1415

Malaysia: No. 76 Jalan Universiti, 46200 PETALING JAYA, SELANGOR,
Tel. +60 3 750 5214, Fax. +60 3 757 4880

Mexico: 5900 Gateway East, Suite 200, EL PASO, TEXAS 79905,
Tel. +9-5 800 234 7381, Fax +9-5 800 943 0087

Middle East: see Italy

Netherlands: Postbus 90050, 5600 PB EINDHOVEN, Bldg. VB,
Tel. +31 40 27 82785, Fax. +31 40 27 88399

New Zealand: 2 Wagener Place, C.P.O. Box 1041, AUCKLAND,
Tel. +64 9 849 4160, Fax. +64 9 849 7811

Norway: Box 1, Manglerud 0612, OSLO,
Tel. +47 22 74 8000, Fax. +47 22 74 8341

Pakistan: see Singapore

Philippines: Philips Semiconductors Philippines Inc.,
106 Valero St. Salcedo Village, P.O. Box 2108 MCC, MAKATI,
Metro MANILA, Tel. +63 2 816 6380, Fax. +63 2 817 3474

Poland: Ul. Lukiska 10, PL 04-123 WARSZAWA,
Tel. +48 22 612 2831, Fax. +48 22 612 2327

Portugal: see Spain

Romania: see Italy

Russia: Philips Russia, Ul. Usatcheva 35A, 119048 MOSCOW,
Tel. +7 095 755 6918, Fax. +7 095 755 6919

Singapore: Lorong 1, Toa Payoh, SINGAPORE 319762,
Tel. +65 350 2538, Fax. +65 251 6500

Slovakia: see Austria

Slovenia: see Italy

South Africa: S.A. PHILIPS Pty Ltd., 195-215 Main Road Martindale,
2092 JOHANNESBURG, P.O. Box 58088 Newville 2114,
Tel. +27 11 471 5401, Fax. +27 11 471 5398

South America: Al. Vicente Pinzon, 173, 6th floor,
04547-130 SÃO PAULO, SP, Brazil,
Tel. +55 11 821 2333, Fax. +55 11 821 2382

Spain: Balmes 22, 08007 BARCELONA,
Tel. +34 93 301 6312, Fax. +34 93 301 4107

Sweden: Kottbygatan 7, Akalla, S-16485 STOCKHOLM,
Tel. +46 8 5985 2000, Fax. +46 8 5985 2745

Switzerland: Allmendstrasse 140, CH-8027 ZÜRICH,
Tel. +41 1 488 2741 Fax. +41 1 488 3263

Taiwan: Philips Semiconductors, 6F, No. 96, Chien Kuo N. Rd., Sec. 1,
TAIPEI, Taiwan Tel. +886 2 2134 2886, Fax. +886 2 2134 2874

Thailand: PHILIPS ELECTRONICS (THAILAND) Ltd.,
209/2 Sanpavuth-Bangna Road Prakanong, BANGKOK 10260,
Tel. +66 2 745 4090, Fax. +66 2 398 0793

Turkey: Yukari Dudullu, Org. San. Blg., 2.Cad. Nr. 28 81260 Umraniye,
ISTANBUL, Tel. +90 216 522 1500, Fax. +90 216 522 1813

Ukraine: PHILIPS UKRAINE, 4 Patrice Lumumba str., Building B, Floor 7,
252042 KIEV, Tel. +380 44 264 2776, Fax. +380 44 268 0461

United Kingdom: Philips Semiconductors Ltd., 276 Bath Road, Hayes,
MIDDLESEX UB3 5BX, Tel. +44 181 730 5000, Fax. +44 181 754 8421

United States: 811 East Arques Avenue, SUNNYVALE, CA 94088-3409,
Tel. +1 800 234 7381, Fax. +1 800 943 0087

Uruguay: see South America

Vietnam: see Singapore

Yugoslavia: PHILIPS, Trg N. Pasica 5/v, 11000 BEOGRAD,
Tel. +381 11 62 5344, Fax.+381 11 63 5777

For all other countries apply to: Philips Semiconductors,
International Marketing & Sales Communications, Building BE-p, P.O. Box 218,
5600 MD EINDHOVEN, The Netherlands, Fax. +31 40 27 24825

Internet: <http://www.semiconductors.philips.com>

© Philips Electronics N.V. 1999

SCA 64

All rights are reserved. Reproduction in whole or in part is prohibited without the prior written consent of the copyright owner.

The information presented in this document does not form part of any quotation or contract, is believed to be accurate and reliable and may be changed without notice. No liability will be accepted by the publisher for any consequence of its use. Publication thereof does not convey nor imply any license under patent- or other industrial or intellectual property rights.

Printed in The Netherlands

545004/750/02/pp32

Date of release: 1999 May 07

Document order number: 9397 750 05317

Let's make things better.

**Philips
Semiconductors**



PHILIPS